

Heavy Duty Worm Drive Clamp

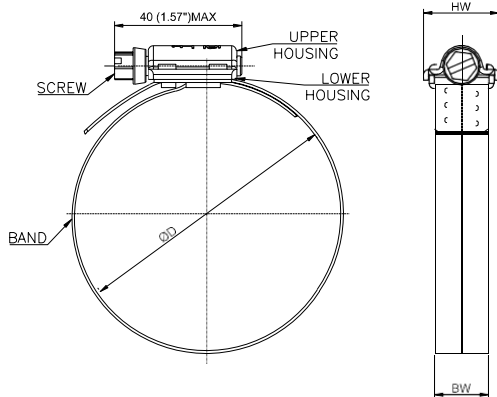

Ref. standard: SAE J1508 Type "HD"

- High strength applications.
- Can withstand at high torque and pressure.
- Recommended for high vibration applications.



Example for Ordering Code

WH M01 B03 212

Design Type

WH

M01

B03

212

Jolly Size

Material Grade

Band width (BW) & Housing width (HW)

* Jolly size ordering codes vary as per SAE & IS/BS sizes.

Short Description

Jolly Heavy Duty Worm Drive Clamp is designed as per SAE standard for High Pressure & vibration applications. Heavy Duty Two-Piece housing construction makes it suitable for high torque applications. Liner prevents direct contact of perforations with hose which prevents hose biting at high installation torque

Design Type Ordering Code : WH

Ordering Code	Material Grade Option
M01	All parts : SS 304
M02	Band & Housing : SS 304 Screw : Plated Carbon Steel
M03	Band & Housing : SS 304 Screw : SS 410
M06	All parts : SS 316
M22	Band & Housing : SS 301 Screw : SS 304
M23	Band & Housing : SS 301 Screw : SS 410
M24	Band & Housing : SS 301 Screw : PCS

Ordering Code	Band Width (BW)
B02	Band : 14 mm (9/16")
B03	Band : 16 mm (5/8")

Jolly sizes as per IS/BS Standard

Jolly Size Ordering Code	IS / BS Sizes	Min Dia (in)	Max Dia (in)	Min Dia (mm)	Max Dia (mm)
J1X	40	1.181	1.575	30	40
J45A	45	1.378	1.772	35	45
J2A	50	1.496	1.969	38	50
J2	55	1.654	2.165	42	55
J2X	60	1.772	2.362	45	60
J65A	65	1.772	2.559	45	65
J3	70	1.969	2.756	50	70
J75A	75	2.165	2.953	55	75
J3X	80	2.362	3.150	60	80
J4	90	2.756	3.543	70	90
J4X	100	3.150	3.937	80	100
J110A	110	3.543	4.331	90	110
J5	115	3.740	4.528	95	115
J5X	120	3.937	4.724	100	120
J6	130	4.331	5.118	110	130
J575 S	145	4.921	5.709	125	145
J6X	160	5.512	6.299	140	160

Additional sizes are available as per enquiry.

Jolly sizes as per SAE Standard

Jolly Size Ordering Code	SAE Sizes	Closed Dia (in)	Open Dia (in)	Closed Dia (mm)	Open Dia (mm)
212	212	1.250	2.125	31.75	53.980
262	262	1.750	2.625	44.45	66.680
312	312	2.250	3.125	57.15	79.380
362	362	2.750	3.625	69.85	92.080
412	412	3.250	4.125	82.55	104.780
462	462	3.750	4.625	95.25	117.480
512	512	4.250	5.125	107.95	130.180
562	562	4.750	5.625	120.65	142.880
612	612	5.250	6.125	133.35	155.600
662	662	5.750	6.625	146.05	168.280
712	712	6.250	7.125	158.75	180.980
762	762	6.750	7.625	171.45	193.680
812	812	7.250	8.125	184.15	206.380
862	862	7.750	8.625	196.85	219.080
912	912	8.250	9.125	209.55	231.780

Additional sizes are available as per enquiry.

Area of Application

Automotive • Engine Application • Earth Moving Equipment
Marine Applications • Oil & Gas Applications

We reserve the right to make technical & Dimensional modifications within Standard specification .
UPC code made available on request.
Packing Specification available.