

# Worm Drive Lined Clamp

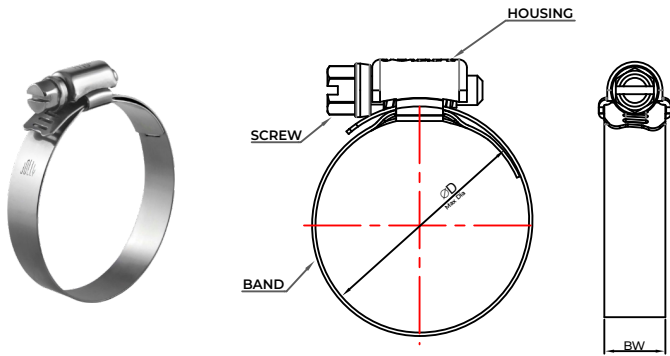

**WL-M01-B03-20**

Example for Ordering Code

- WL** → Jolly Design Code
- M01** → Material Code
- B01** → BandWidth Code (BW)
- 20** → Jolly Size

BandWidth Code	BandWidth Size (BW) Options
B01	Band : 12.7 mm
B02	Band : 14.3 mm
B03	Band : 16 mm

Material Code	Material Grade Option		
	Band	Housing	Screw
M01	SS 304	SS 304	SS 304
M02	SS 304	SS 304	PCS
M03	SS 304	SS 304	SS 410
M04	SS 201 / 202	SS 201 / 202	SS 304
M06	SS 316	SS 316	SS 316
M07	SS 201 / 202	SS 201 / 202	PCS
M14	SS 201 / 202	SS 201 / 202	SS 410
M22	SS 301	SS 301	SS 304
M23	SS 301	SS 301	SS 410
M24	SS 301	SS 301	PCS

PCS : Plated Carbon Steel

Jolly Size	IS / BS Sizes	Max Dia (in)	Min Dia (in)	Max Dia (mm)	Min Dia (mm)
J1X	40	1 4/7	1 1/6	40	30
J45A	45	1 7/9	1 3/8	45	35
J2A	50	2	1 1/2	50	38
J2	55	2 1/6	1 2/3	55	42
J2X	60	2 1/3	1 7/9	60	45
J65A	65	2 5/9	1 7/9	65	45
J3	70	2 3/4	2	70	50
J75A	75	3	2 1/6	75	55
J3X	80	3 1/7	2 1/3	80	60
J4	90	3 1/2	2 3/4	90	70
J4X	100	4	3 1/7	100	80
J110A	110	4 1/3	3 1/2	110	90
J5	115	4 1/2	3 3/4	115	95
J5X	120	4 5/7	4	120	100
J6	130	5 1/8	4 1/3	130	110
J575 S	145	5 5/7	5	145	125
J6Z	160	6 2/7	5 1/2	160	140

\*Additional sizes available as per enquiry\*

Jolly Size	SAE Sizes	Max Dia (in)	Min Dia (in)	Max Dia (mm)	Min Dia (mm)
6	6	7/9	5/9	19.8	14
8	8	77/84	2/3	23.1	17
10	10	1	3/4	26.9	19
12	12	1 1/4	6/7	31.7	22
16	16	1 1/2	1	38.1	25
20	20	1 3/4	1 1/9	44.4	28
24	24	2	1 1/4	50.8	32
28	28	2 1/4	1 1/3	57.1	33.3
32	32	2 1/2	1 5/9	63.5	39.6
40	40	3	2	76.2	52.3
48	48	3 1/2	2 5/9	88.9	65
64	64	4 1/2	3 5/9	114.3	90.4
72	72	5	4	127.0	103.1

\*Additional sizes available as per enquiry\*

Torque Details	Band width (mm)	9	12.7, 14.3, 16
	Idling Torque (N-m)	0.45	0.45
	Application Torque (N-m)	SS202-3.5 SS304-3.5	PCS-4.2/304-5.1/410-5.1
	Durability Torque (N-m)	SS202-4 SS304-4	PCS-5.6/304-6.8/410-6.8
	Ultimate Breaking Torque (N-m)	SS202-4.5 SS304-4.5	PCS-10/304-15/410-15

Note: Maximum application torque is 75% of ultimate breaking torque